



Date:  
7/2/2018

Weights:  
49lbs/22.23kg

Units:

Part Number:  
ECD-SRT12CA-D2EH

Submitted To: [guest@micrometl.com](mailto:guest@micrometl.com)

Job:

Notes:

Economizer - Ultra Low Leak Economizer, Vertical Orientation, Honeywell Jade W7220 Single/Multiple Speed Electromechanical Controller, Enthalpy Sensor, Honeywell Actuator. Painted Rain Hood With Aluminum Filter, Barometric Relief, All Necessary Panels And Hardware Included.

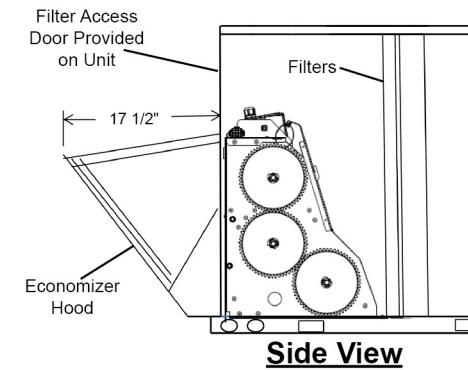
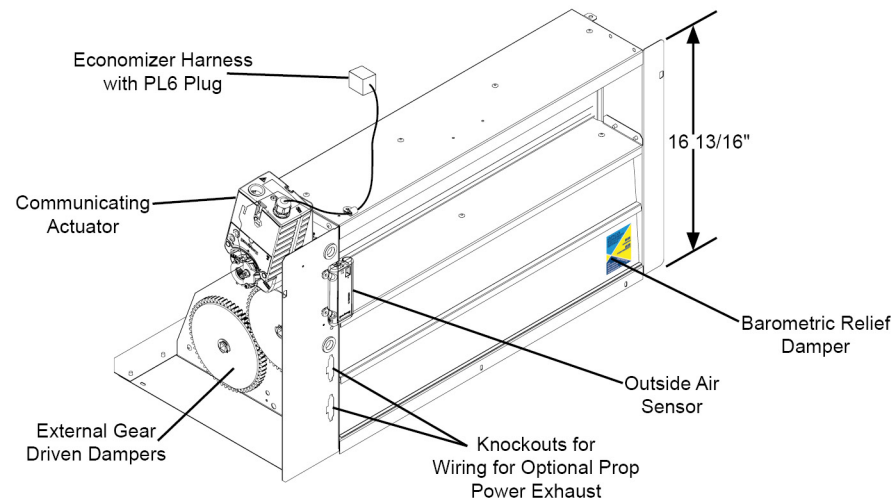

The Information contained in this drawing is the sole property of Micrometl Corporation. Any reproduction in part or whole without the written permission of Micrometl Corporation is prohibited.

Indianapolis\_3035 N. Shadeland Ave., Indianapolis, IN 46226\_800.MMC.HVAC • Sparks\_905 Southern Way, Sparks, NV 89431\_800.884.4MMC • Longview\_201 Kodak Blvd., Longview, TX 75602\_903.248.4800



**MicroMetl**

Date:  
7/2/2018

Weights:  
49lbs/22.23kg

Units:

Part Number:  
ECD-SRT12CA-D2EH

Submitted To: guest@micrometl.com

Job:

Notes:

Economizer - Ultra Low Leak Economizer, Vertical Orientation, Honeywell Jade W7220 Single/Multiple Speed Electromechanical Controller, Enthalpy Sensor, Honeywell Actuator. Painted Rain Hood With Aluminum Filter, Barometric Relief, All Necessary Panels And Hardware Included.

**Compliant Economizer:**

1. **Title 24:** Economizers meet California Energy Commission Title 24-2013 / 2016 prescriptive section 140.4 (damper leakage etc.), and mandatory section 120.2.i for Fault Detection and Diagnostic controls (JADE HJW10).
2. **ASHRAE 90.1:** Economizers meet ASHRAE 90.1-2013 / 2016 damper leakage requirements, and meet 2016 Fault Detection and Diagnosis requirements.
3. **IECC:** Economizers meet IECC 2012, IECC 2015, and IECC 2018 for outside air, return air, and relief damper (when provided) leakage requirements, and IECC 2015 and IECC 2018 for Fault Detection and Diagnostic requirements. Note: IECC 2015 and IECC 2018 requires differential return air sensor, which is included in some models (i.e. D2XH) and must be ordered separately on others (i.e. D2DH, D2ZH).
4. **AMCA:** Outside air and return air (volume) dampers are AMCA Class 1A rated at 1" w.g. Refer to MicroMetl NS1 catalog sheet on web site for details. Relief air dampers (when provided) are also AMCA rated. Refer to GR1 series catalog sheet on web site for details.

**Features:**

- For single or 2 speed indoor fan units with Central Terminal Board (CTB) and Compressor Staging Board. Other control options available.
- Gear driven design for trouble-free operation, eliminating slippage and binding associated with standard linkage.
- Includes assembled rainhood with aluminum water entrainment filters in the outside air section.
- Rainhood is sloped for water run-off.
- Built-in barometric relief damper provided. Power exhaust options available.
- All harnesses and plugs needed are provided.
- Uses standard factory filter access door shipped with HVAC unit.
- If factory hinged access door option is installed on unit, an additional kit is required to seal hinged door properly.
  - OEM part no. CRPECONV003A00 or MicroMetl part number 0640-0100-HDANGL

**Notes:**

1. Control systems include Honeywell W7220 JADE controller, mixed (supply) air temperature sensor, OA sensor in description, and spring-return communicating actuator (some include differential return sensor as noted).
2. JADE W7220 controller is field mounted in unit's control box.
3. Mixed (supply) air sensor is field installed in indoor blower fan section.
4. Differential return sensor (included in "-D2XH" and "-D2ZH" models or can be ordered separately - MicroMetl Part No. 9901-2022-DIFF JC2) is field installed in return duct.
5. ASHRAE, IECC, and Title 24 require the economizer controller be capable of reporting faults to a fault management application accessible by day-to-day operating or service personnel, or annunciated locally on zone thermostats or in some codes other devices are acceptable. Refer to applicable code requirements and to MicroMetl instructions for suggestions.
6. For older single speed models without the Central Terminal Board the "-D2" part number is replaced by "-DJ". (See separate submittal).



MicroMetl Corporation certifies that the models GR1 and NS1 shown herein are licensed to bear the AMCA Seal. The ratings shown are based on tests and procedures performed in accordance with AMCA Publication 511 and comply with requirements of the AMCA Certified Ratings Programs. The AMCA Certified Ratings Seal applies to Air Leakage and Air Performance ratings.

The Information contained in this drawing is the sole property of Micrometl Corporation. Any reproduction in part or whole without the written permission of Micrometl Corporation is prohibited.